

RAINBOSS FEATURES:

- Primex's RainBoss Flashing System conforms with Building Code requirements for the RainScreen envelopes.
- Designed to for maximum effectiveness in fight against the moisture retention.
- Provides proper ventilation of the building envelope.
- Recommended solution for implementation of RainScreen building envelope construction.

RAINBOSS ADVANTAGES:

- UV resistant polymeric material eliminates permanent bends and nicks, keeping uniform shape throughout the lifetime of the building.
- RainBoss eliminates labor intensive on-site guess work and excessive customization.
- Time saving easy installation.
- Protects RainScreen cavity against bug infestation.
- Ensures correct implementation of the Rainboss RainScreen Flashing System.

A DEAW12 – Above Window Flashing System

B DEBW12 – Below Window Flashing System

C DEBF12 – Between Floors Flashing System

D DETW12 – Soffit Venting Strip

RAINBOSS

RAINSCREEN FLASHING SYSTEM

PRIMEX
MANUFACTURING

DEAW12 – Above Window Flashing

RAINSCREEN COMPLIANT



Above Window
Endcap: DEAWC

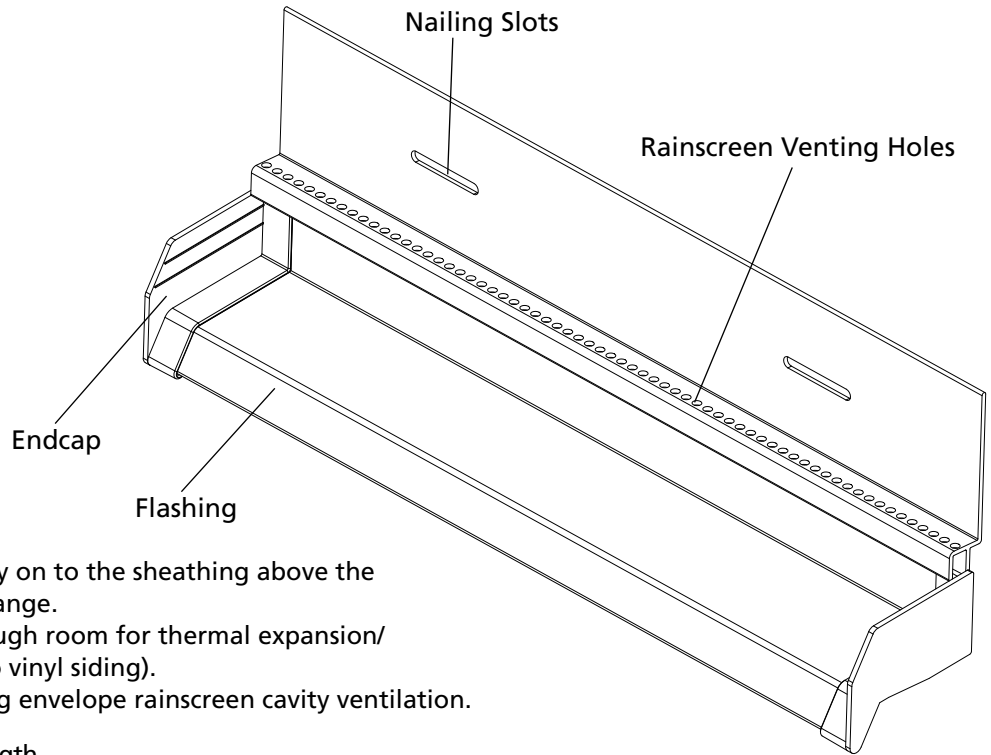

FEATURES:

- The extruded flashing installs directly on to the sheathing above the window framing using the nailing flange.
- Elongated nailing holes provide enough room for thermal expansion/ shrinkage of the extrusion (similar to vinyl siding).
- Integrated bug screen allows building envelope rainscreen cavity ventilation.

SIZE: All profiles available in 12 ft. length

DEBW12– Below Window Flashing

RAINSCREEN COMPLIANT

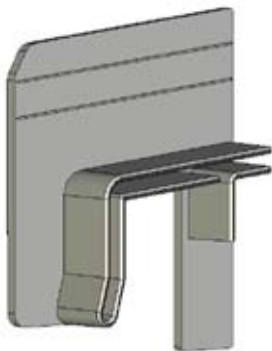

Below Window
Endcap: DEBWC

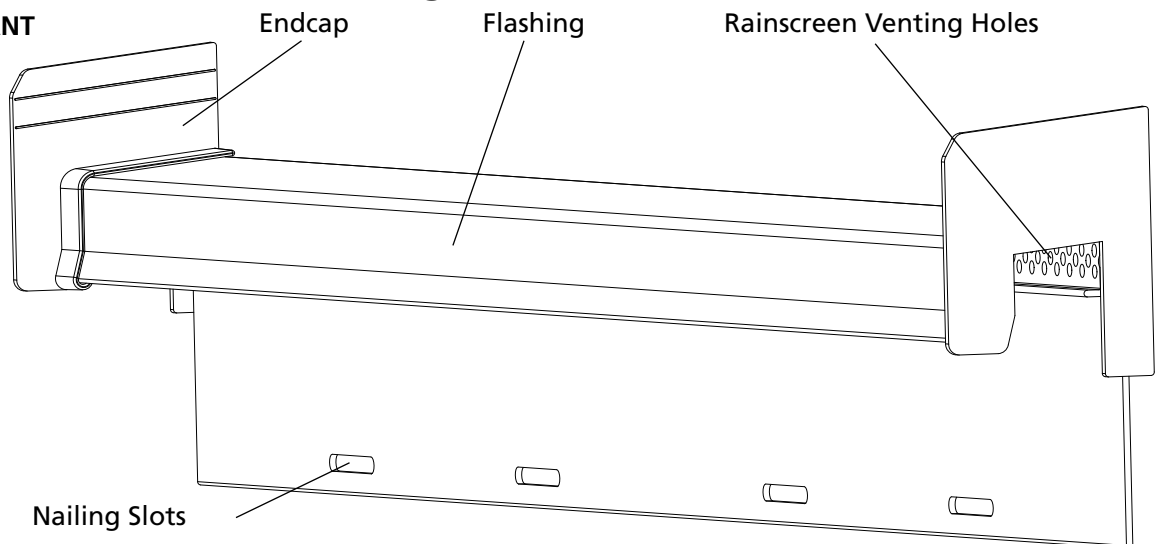

FEATURES:

- Redirects free water to the exterior cladding.
- Integrated bug screen allows building envelope rainscreen cavity ventilation and prevents insect access to the rainscreen cavity at the same time.
- Mounts directly onto rainscreen strapping.

SIZE: All profiles available in 12 ft. length

PRIMEX MANUFACTURING USA
TEL: (360) 332 3100
FAX: (360) 332-3200

WWW.PRIMEX.CA
SALES@PRIMEX.CA
TOLL FREE: 1-877-881-7875
FAX: 1-877- 881-7835

PRIMEX MANUFACTURING CANADA
TEL: (604) 881-7875
FAX: (604) 881-7835

DEBF12 – Between Floors Flashing System

RAINSCREEN COMPLIANT

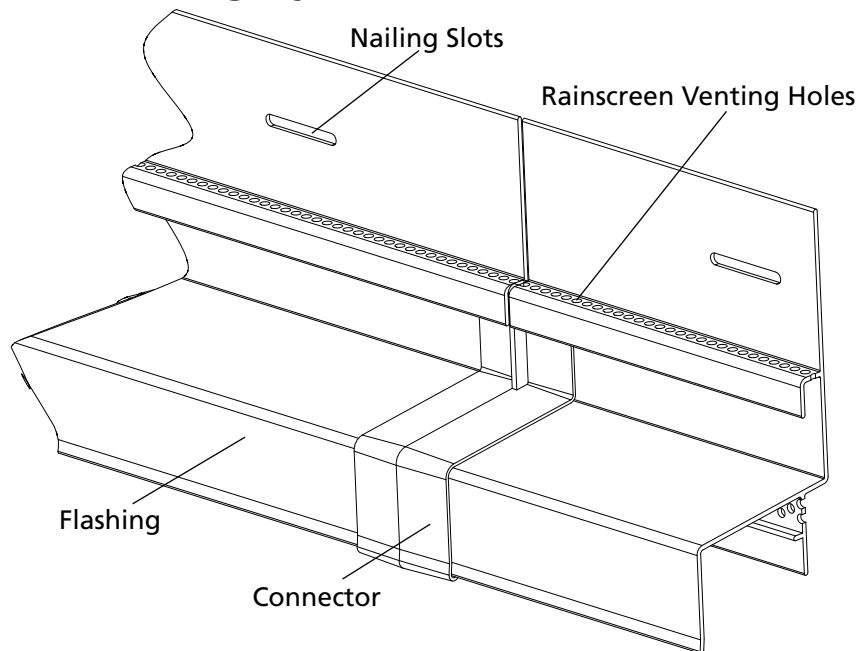
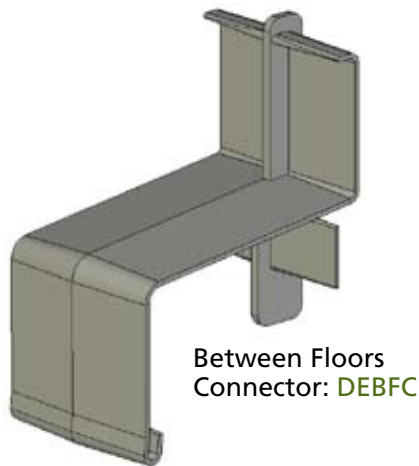

FEATURES:

- Mounts directly onto the building sheathing.
- Integrated top and bottom bug screen provides free air ventilation of the rainscreen cavity above and below flashing and prevents insect access to the rainscreen cavity.
- Accommodates 2x10 trim boards.

SIZE: All profiles available in 12 ft. length

DETW12 – Soffit Venting Strip

RAINSCREEN COMPLIANT

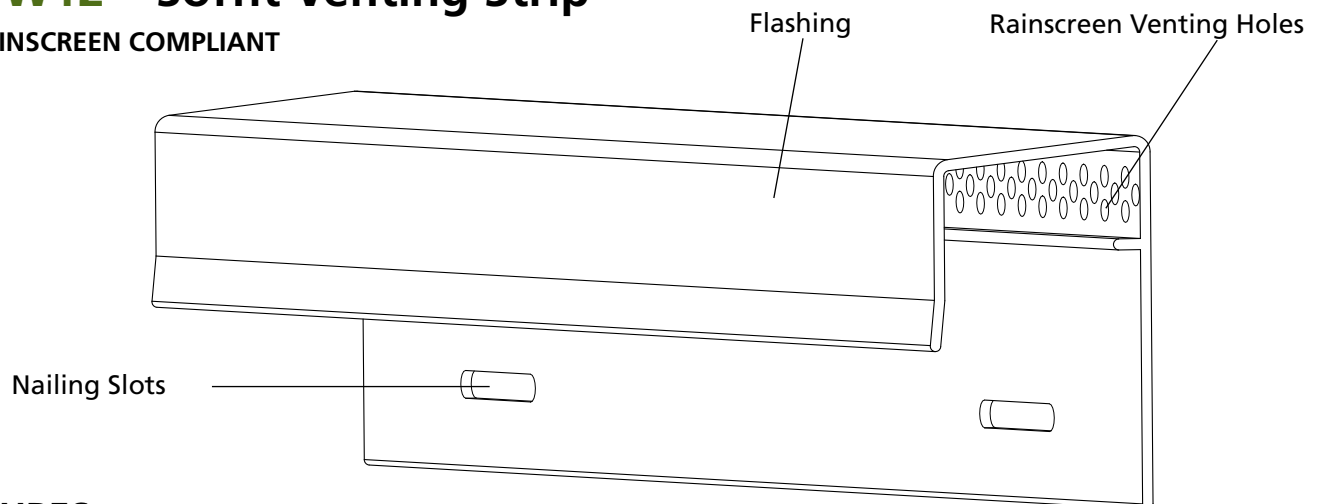

FEATURES:

- Allows ventilation of vertical rainscreen wall along the full length of a building into the external space rather than the horizontal soffit space.
- Effective on flat wall lines as well as angled gable walls with no soffit or eaves for protection.
- Integrated bug screen prevents insect access to the rainscreen cavity.
- Mounts directly onto rainscreen cavity strapping.

SIZE: All profiles available in 12 ft. length